



USER'S MANUAL DC-SERVO-DRIVER TFMxx0 BY USING THE OPTIONAL EQUIPMENT IxR-COMPENSATION TFZ06 (ON BOARD)

- 0 PRECAUTIONS ON SAFETY (DEFINITIONS)**
- 1 INTRODUCTION**
- 2 POSSIBILITIES OF ADJUSTMENT AND LOGIC SIGNALS**
 - 2.1 Devices for Adjustment**
 - 2.1.1 Speed (P1)
 - 2.1.2 Speed Controller Gain (P2)
 - 2.1.3 Current Limit (P3)
 - 2.1.4 Offset (P4)
 - 2.1.5 Integration Rate Speed Controller (C2)
 - 2.1.6 Continuous Current (R6)
 - 2.1.7 Peak Current (R4)
 - 2.1.8 Control Voltage (R5)
 - 2.1.9 Current Monitor (DIN41612)
 - 2.1.10 Set up the Common Fault Monitor (ST2)
 - 2.1.11 Set up the Running Mode (ST1) and fix current limit
 - 2.2 Logic Signals**
 - 2.3 Possibilities of Adjustment on Option IxR-COMPENSATION TFZ06**
 - 2.3.1 Adjustment to the Power Voltage (R1)
 - 2.3.2 Adjustment to the Resistor of the Motor Armature Windings (R2)
- 3 OPERATING OF TFMxx0 BY USING THE OPTIONAL EQUIPMENT IxR-COMPENSATION TFZ06**
 - 3.1 Before Power On**
 - 3.2 Put into Operation and Adjustment**
 - 3.3 To take into Account**

0 PRECAUTIONS ON SAFETY (DEFINITIONS)

DANGER *immediately and imminent DANGER for life and limb*
(possibly including the PRECAUTIONS ON SAFETY WARNING and NOTICE)

WARNING *possibility of a dangerous situation for life and limb*
(possibly including the PRECAUTION ON SAFETY NOTICE)

NOTICE *possibility of a dangerous situation for the TFMxx0 or an object in its area*

DANGER: Possibility of an electric shock. The nonobservance of the instructions and the precautions on safety written down in this manual shall produce immediately and imminent danger for life and limb or for the TFMxx0 or an object in its area. The handling including mounting, installation and operating has to be carried out by well trained and instructed personal..

1 INTRODUCTION

WARNING: To ward off accidents given by electric shock or destruction of TFMxx0 or an object in its area the instructions and the precautions on safety written down in this manual have to be red and fulfilled before mounting, installation and operating the TFMxx0. This manual is a part of the **USER'S MANUAL DC-SERVO-DRIVER TFMxx0-STANDARD**. Both manuals have to be used during handling, mounting, installation and operating.

By using the TFMxx0 with the optional equipment **IxR-COMPENSATION TFZ06** the rotor speed (the actual value is the electromotive force of the motor) is related to the Control Input Voltage (rated value). Therefore no external speed sensor is required. The related accuracy is approximately 5%.The output current is limited.

2 POSSIBILITIES OF ADJUSTMENT AND LOGIC SIGNALS

WARNING: To ward off accidents given by electric shock or destruction of TFMxx0 or an object in its area the instructions and the precautions on safety written down in this manual have to be red and fulfilled before mounting, installation and operating the TFMxx0.

2.1 Devices for Adjustment

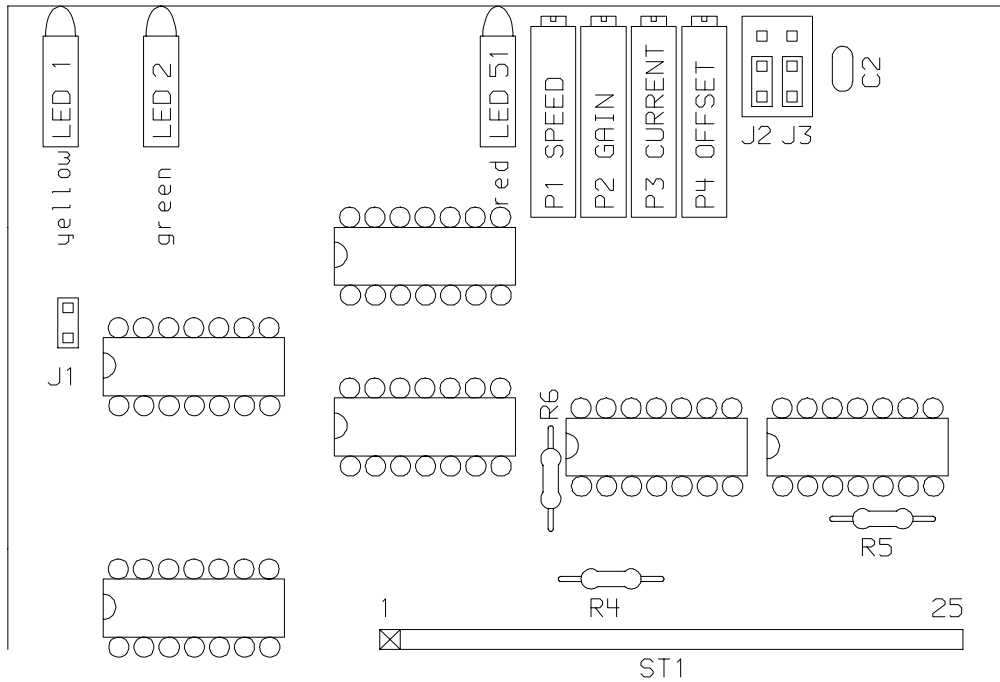

	name	element	no.
1	Speed	potentiometer	P1
2	Speed Controller Gain	potentiometer	P2
3	Current Limit	potentiometer	P3
4	Offset	potentiometer	P4
5	Integration Rate Speed Controller	capacity	C2
6	Continuous Current	resistor	R6
7	Peak Current	resistor	R4
8	Current Monitor	connector	DIN41612
9	Control Voltage	resistor	R5
10	Set up the Common Fault Monitor	jumper	ST2
11	Set up the Running Mode	jumper	ST1

2.1.1 Speed (P1)

To adjust the speed (actual value) in relation to the rated value (Control Voltage). Turning the potentiometer **clock wise** results in a lower damping of the signal (e.g. low speed).

2.1.2 Speed Controller Gain (P2)

To adjust the gain of the Speed Controller. Turning the potentiometer **clock wise increases the high frequency gain. NOTICE: To ward off destruction of the motor (warm up) doe carefully adjust the gain.**

2.1.3 Current Limit (P3)

To adjust the peak current. Turning the potentiometer **clock wise** to the end touch results in the **maximum peak current**. Turning the potentiometer **counter clock wise decreases the peak current**.

2.1.4 Offset (P4)

To adjust the motor speed to zero (common short circuit of both Control Inputs required). May be that temperature floating makes necessary a correction of first adjustment.

2.1.5 Integration Rate Speed Controller (C2)

To adjust the integration rate of Speed Controller. Increased capacity values results in a slower reaction of the Speed Controller. **NOTICE: To ward off destruction of the motor (warm up) doe carefully change the capacity value.**

2.1.6 Continuous Current (R6)

To adjust the continuous current. The following requirements are fulfilled in standard TFMxx0:

Type	maximum continuous current [A]
TFMxx0-06-	6
TFMxx0-08-	8
TFMxx0-10-	10

Increasing the value of R6 decreases the value of maximum continuous current. **NOTICE: It is not allowed to increase the continuous current. To ward off destruction of the motor never cross its current limit given by the manufacturer.**

2.1.7 Peak Current (R4)

To adjust the peak current. The following requirements are fulfilled in standard TFMxx0:

Type	maximum peak current [A]
TFMxx0-06-	12
TFMxx0-08-	16
TFMxx0-10-	20

NOTICE: It is not allowed to increase the peak current. To ward off destruction of the motor never cross its current limit given by the manufacturer

2.1.8 Current Monitor (DIN41612)

To monitoring the current signal during adjustment connect an oscilloscope.

NOTICE: The output of the integrated circuit is laid out for small loads only.

2.1.9 Control Voltage (R5)

To adjust the sensitivity of the Control Voltage Input (rated value). To increase the sensitivity of the Control Voltage Input decrease the value of R5.

2.1.10 Set up the Common Fault Monitor (ST2)

To set up the Common Fault Monitor connect a jumper to both connectors of ST2.

2.1.11 Set up the Running Mode (ST1) and Fix Current Limit

To set up the Running Mode by using the TFMxx0 with the optional equipment IxR-COMPENSATION TFZ06 connect the jumpers on ST1 as follows:

- see the top view of the layout under 2.1 Devices for Adjustment
- connect the jumpers in configuration for speed controller and select the Fix Current Limit 50% or 100% (the Fix Current Limit depends on customers' requirements)

2.2 Logic Signals

name	element	action	relation to the axles
Common Fault Monitor	transistor	conducting in the case of a failure	common output
Enable-Output	transistor	not conducting in the case of a failure	each axle is equipped with an own output
Enable-Input	resistor	to set up the function a high signal is required	each axle is equipped with an own input

2.3 Possibilities of Adjustment on Option IxR-COMPENSATION TFZ06

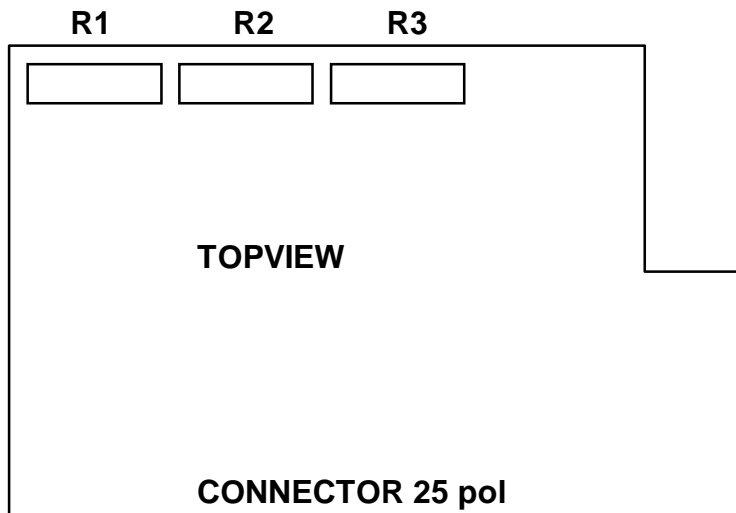

	name	element	no.
1	Adjustment to the Power Voltage	resistor	R1
2	Adjustment to the Resistor of the Motor Armature Windings	resistor	R2

WARNING: Possibility of a miss function or accidents. Never change or adjust any other device on the IxR-COMPENSATION TFZ06.

2.3.1 Adjustment to the Power Voltage (R1)

To adjust the optional equipment IxR-COMPENSATION TFZ06 to the standard voltage of TFMxx0.

Type	standard voltage [V]	value of R1 [kOhm]
TFM060-	60	68
TFM090-	90	43
TFM120-	120	33
TFM150-	150	27

WARNING: Possibility of a miss function or accidents. The value of R1 has to be in accordance with the standard voltage.

2.3.2 Adjustment to the Resistor of the Motor Armature Windings (R2)

To adjust the optional equipment IxR-COMPENSATION TFZ06 to the resistor of the motor armature windings.

$R2 \text{ [kOhm]} = K \times \text{the value of the resistor of the motor armature windings [Ohm]}$

Type	standard voltage [V]	K
TFM060-	60	2.4
TFM090-	90	1.5
TFM120-	120	1.2
TFM150-	150	1.0

WARNING: Possibility of a miss function or accidents. The value of R2 has to be in accordance with the standard voltage and the resistor of the motor armature windings.

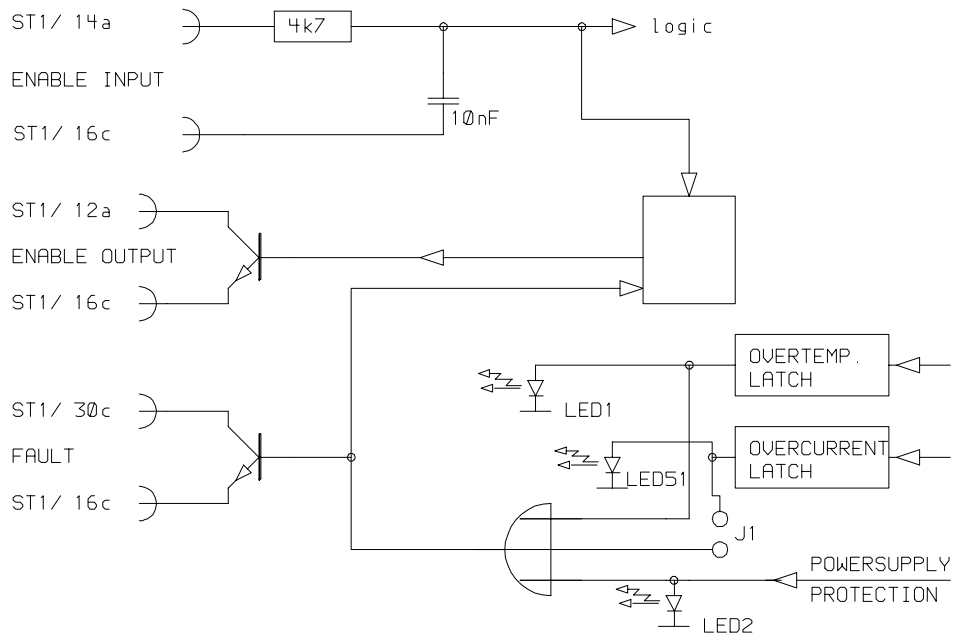
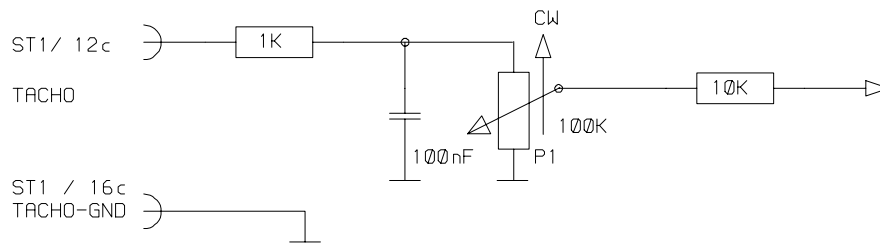
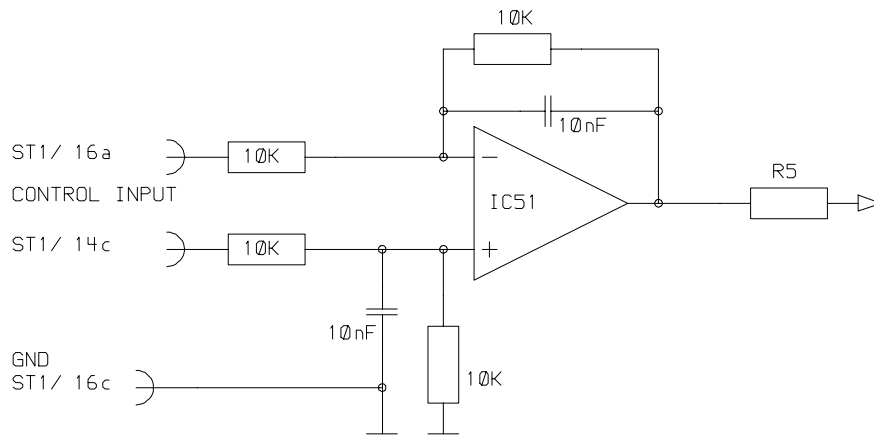

3 OPERATING OF TFMxx0 BY USING THE OPTIONAL EQUIPMENT IxR-COMPENSATION TFZ06

DANGER: Possibility of an electric shock. The nonobservance of the instructions and the precautions on safety written down in this manual shall produce immediately and imminent danger for life and limb or for the TFMxx0 or an object in its area. The handling including mounting, installation and operating have to be carried out by well trained and instructed personnel. Measuring instruments has to be connected without electric power. To discharge the capacities the operator has to wait 2 minutes after switch off the power before any manipulation is carried out. To protect the operator the potentiometers has to be adjusted with an isolated screw driver (blade and shank).

WARNING: To ward off accidents given by electric shock or destruction of TFMxx0 or an object in its area the instructions and the precautions on safety written down in this manual have to be red and fulfilled before mounting, installation and operating the TFMxx0 (e.g. chapter 2 POSSIBILITIES OF ADJUSTMENT). The TFMxx0 are delivered in defined adjustment. It is not allowed to change specific adjustments given by customer requirements. Variations (e.g. to fulfil customer requirements) of TFMxx0 have different identification numbers.

3.1 Before Power On

WARNING: To ward off accidents given by electric shock or destruction of TFMxx0 or an object in its area the instructions and the precautions on safety written down in this manual have to be red and fulfilled before mounting, installation and operating the TFMxx0.

Before power on the following requirements have to be fulfilled:

A) Preadjustments

name	element	no.	preadjustment
Speed	potentiometer	P1	clock wise to the end touch
Speed Controller Gain	potentiometer	P2	medium
Current Limit	potentiometer	P3	medium
Offset	potentiometer	P4	medium

B) The Enable Inputs has to be connected together (0V between the two connectors).

C) No signal at the Control Voltage Input (0V between the two connectors).

D) Power and intermediate circuit voltage has to be checked.

E) Cooling in the case (e.g. ventilator) runs correct.

F) Switch the power off.

DANGER: Possibility of an electric shock. Measuring instruments has to be connected without electric power. To discharge the capacities the operator has to wait 2 minutes after switch off the power before any manipulation is carried out. To protect the operator the potentiometers has to be adjusted with an isolated screw driver (blade and shank).

3.2 Put into Operation and Adjustment

DANGER: Possibility of an electric shock. Measuring instruments has to be connected without electric power. To discharge the capacities the operator has to wait 2 minutes after switch off the power before any manipulation is carried out. To protect the operator the potentiometers has to be adjusted with an isolated screw driver (blade and shank).

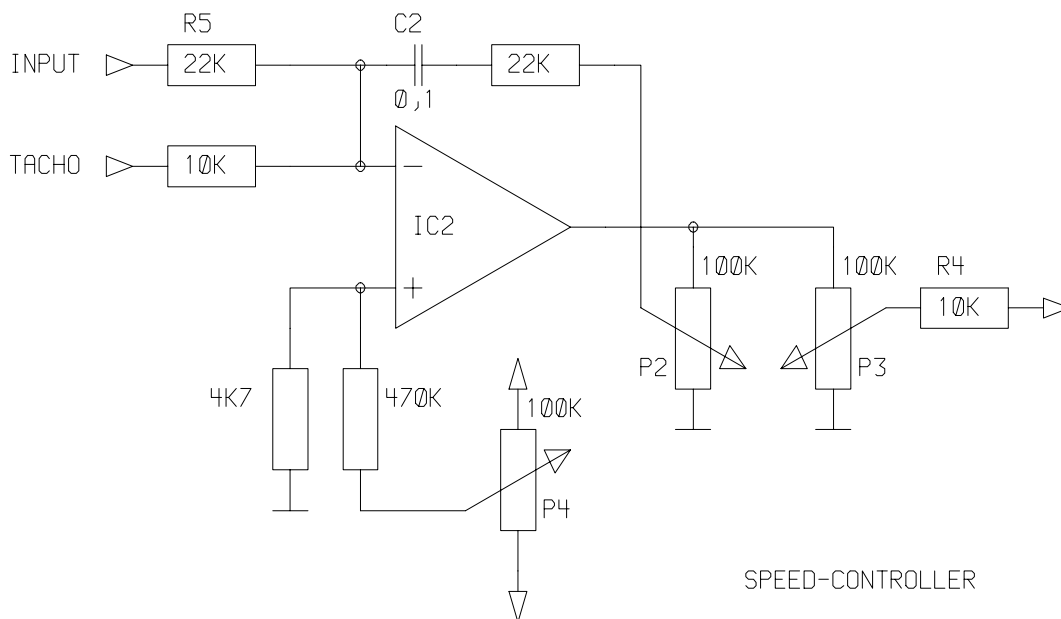

A) Step by step carry out the step 3.1.

B) Connect the TFMxx0. After switch on the power the following requirements have to be fulfilled:

- I **LED green** (intermediate circuit voltage) **has on after 3 seconds.**
- II **After step I only the LED green has on. The other LED's have to be inactive.**

C) Have special attention during the first put into operation. *WARNING: To ward off accidents given by electric shock or destruction of TFMxx0 or an object in its area (e.g. machines or electric equipment) the following instructions have to be carried out step by step.*

I Equipment to detect end touches and other security elements and cooling equipment have to be installed, controlled and tested.

II To check the polarities is a requirement for correct operation of the TFMxx0.

- a) No signal at the Control Voltage Input. (0V between the two connectors).
- b) Switch on the Enable Input (high signal) to set up the function of TFMxx0.
- c) After step II.b) the motor speed is very low or zero.
- d) To control the direction of the rotor in relation to the Control Input Voltage slowly increase the Control Input Voltage (rated value). If the direction is wrong **two possibilities** to change it are given:

- Change the polarity of the connectors of the Control Input.
- Change the polarity of the connectors of the motor
- After this operation go back to the step 3.2.C.

D) To ensure a correct operation of TFMxx0 the adjustment has to be carried out with high attention. To monitor the current signal at the Current Monitor an oscilloscope has to be used. **NOTICE: It is possible that an incorrect adjustment results in destruction of the motor or objects in its area.**

I The Offset has to be adjusted as follows:

- a) Short circuit the two connectors of the Control Input and connect it to the signal GND (e.g. tacho GND). **NOTICE: It is possible that this short circuit destroys the rated value equipment.**
- b) After switch on the power and the Enable Input (high signal) adjust the offset (P4).
- c) Undo the actions done in step I.a). To check correct function repeat step 3.2.C.

II To adjust the maximum rotor speed a signal at the Control Input is needed. The voltage range depends on the source. The maximum value is +/-10VDC.



- a) After switch on the power and the Enable Input (high signal) **slowly increase** the Control Input Voltage watching the rotor speed.
 - b) Adjust the Speed (P1) step by step. To achieve the correct rotor speed in relation to the rated value repeat the steps II.a) and II.b) as long as necessary. Adjust the rotor speed higher (approximately 10%) **to achieve an increased precision in positioning systems.**
- III Adjust the peak current (Current Limit P3) watching the current signal (Current Monitor) during acceleration.
- IV **To optimise the dynamic characteristics of the system** carry out the following actions:
- a) Connect a signal (2Hz) to the Control Input.
 - b) Set the amplitude of the signal (IV.a) like the value needed for a medium rotor speed.
 - c) Adjust the Speed Controller Gain (P2) step by step to achieve the fastest respond. **NOTICE:** *It is possible that an excessive current ripple (to high gain) increases the motor temperature.*
 - d) Vary the amplitude of the signal (IV.b) to have different rotor speeds and watch the respond. If necessary readjust the Speed Controller Gain (P2).

3.3 To take into Account

A) If the TFMxx0 is well adjusted before mounting and installation there is no more adjustment necessary after mounting and installation. It may be necessary to repeat the step 3.2.C).

B) Change the value of C2 if it is not possible to adjust the respond (3.2.D)IV) by the Speed Controller Gain (P2).

C) If the manufacturer changes performances, mounting, installation or operating given by customers request the differences are written down in the product documents (plans, part lists and so on).

D) Contact the manufacturer in the case of unclerness or having troubles.

CH-8200 Schaffhausen
the 26th of January 1998
the General Manager

Lucas Egloff